

Standard

ISO 7500-1, ASTM E4 , ASTM D-76, DIN5122 , JIS B7721/B7733 , EN 1002-2, BS1610,GB T228

Industry

Paper, Tape, Electronics, Medical, Package and others

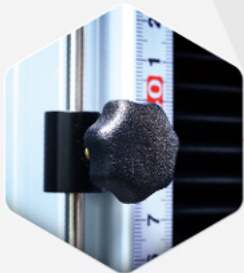

Limit Switch

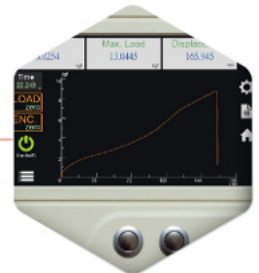

Display



Common Joint for Both Tensile and Compression Test



Up and Down Button



Machine Description

QC-526D2 is a table-type UTM with a big test space and long stroke, the max. capacity is 20kN. It's suitable for testing huge samples, and the new function expansion is acceptable. QC-526D2 is high accuracy and able to connect with the additional accessories.

The D2 software can be used under the Windows system and control the machine through a personal PC or laptop. It can support tensile, compression, bending, peeling tests, and so on. The dedicated software is easy for learning and operation, it supports switching between different languages, Imperial/Metric units and display instant curve. For the complete analysis, the software can export full test data, raw data and reports.

Machine Specification

Force Resolution

Force Resolution	23	bits
Force Precision	0.5%/1% (Note 1)	
Stroke Resolution	0.001	mm
Data Sampling Rate	3-1200	Hz
AD Input Signal	1	set
Encoder Input Signal	1	set

Transmission System

Motor	300W 24V DC motor drives	
Speed Range	1.0-600.0	mm/min
Speed Precision	2.0-5.0±3%	mm/min
	5.0-600.0 ±1%	mm/min

Data Processing System

Network Protocols	TCP/IP	
Analysis Modules in Display	9	
Language in Display	Chinese, English, Japanese, Polish	
Analysis Modules in Optional Software	Over 170	
Language in Optional Software	Chinese, English, Japanese, Korean, Spanish	

Safety Mechanism

Hardware Protection	Upper/Lower limit, emergency stop button	
Protection in Optional Software	Force, displacement, time protection	
CE Marking	Machinery Directive 2006/42/EC	

Electrical Specification

Power Supply	Single phase 100-240V, 5A	W
Max. Power	1100	

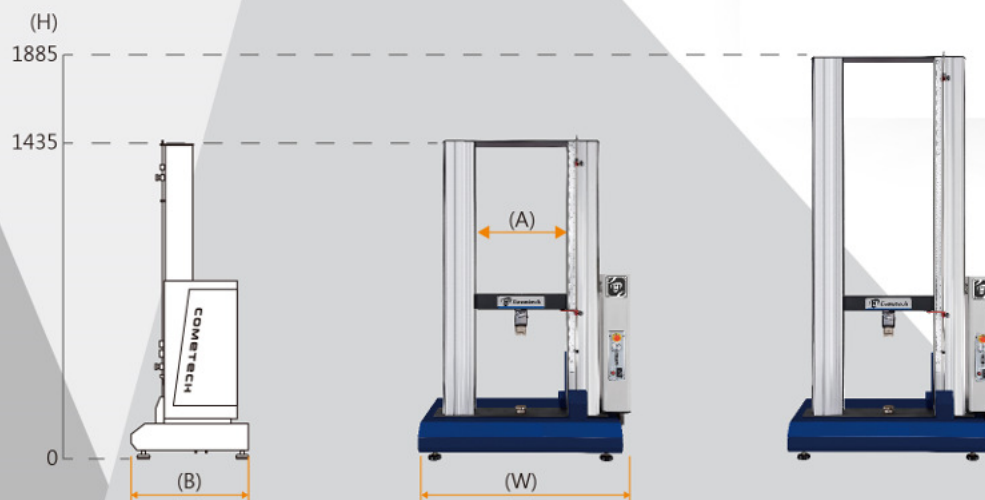

Model	QC-526-M	QC-526-L	
Capacity	20	20	kN
Test Stroke	800	1200	mm
Test Space	425	425	mm
Stiffness	15.85	15.85	kN/mm
Width (W)	940	940	mm
Depth (B)	530	530	mm
Height (H)	1435	1885	mm
Weight	130	185	kg

Note 1: depends on the precision of chosen loadcells

Simpler Operation with Various Functions

The D2 series can be used for real-time measurement on the production line. It can also be connected to a computer for complete control, data analysis and other functions.

The diversity of the machine allows the users to expand new accessories and improve functionality at any time. After setting the test conditions, the test can be completed with one click.

The 100-240V power supply reduces the restrictions of the use environment and region.

7-Inch Touch Screen

- Basic test methods: tensile/ compression/ peeling
- Automatic analysis of specimen information
- Test condition memory and one-click to start test
- Real-time display of force-displacement or force-time graphs
- Metric and imperial unit selection
- Stroke, force and time limit protection
- Breakpoint stop and automatic return
- Storage up to 50 data
- Load calibration
- Language: Chinese, English and Japanese

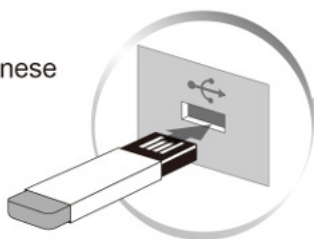

Force-displacement Analysis

Signal input with force-displacement and high-speed data capture capability up to 1000Hz or more, making test results more accurate and force/displacement-related data accessible.

Data Integration and Drive System

The D2 controller is connected to the motor expansion board, which not only allows the controller to receive and analyze the test data, but also directly control the machine.

Set the test conditions before the test, and the machine will automatically complete the functions of test, stop, return and result analysis.



Digitalized Speed Setting

With closed-loop technology, the dedicated motor driver optimizes motor control to make it run like a servo motor.

The test speed can be entered on the controller or in the software, providing better speed range and precise speed control.

Print Function

In stand-alone operation, simple test results like maximum force and maximum deformation can be printed on a sheet at the end of test.

Optional Accessories - Software

- The data sampling rate is up to 1200 Hz..
- Analyze data.
- Windows system required.
- Chinese, English, Japanese, Korean, Spanish are available.
- Operation Mode: TCP/IP two-way transmission to connect with PC.
- Can import multiple test data and display at the same time.
- Supports Metric and Imperial units switching.
- Provides a flexible table for data analysis.
- Can name the data results.
- Data can be shown through the table, graph, or both.
- Data processing: save, import, list, statistical comparison, and so on.
- The X-Y axis of the graph can be set as force, elongation, displacement, time, stress, strain, and so on.
- Tensile, compression, bending, peeling and others are available.
- Supports over travel, overload, over time stop conditions as machine protection.



Report Format

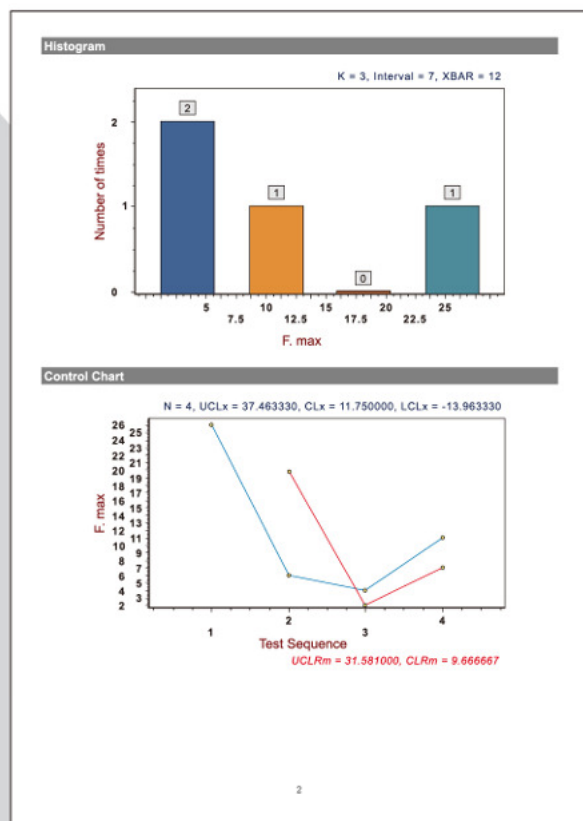
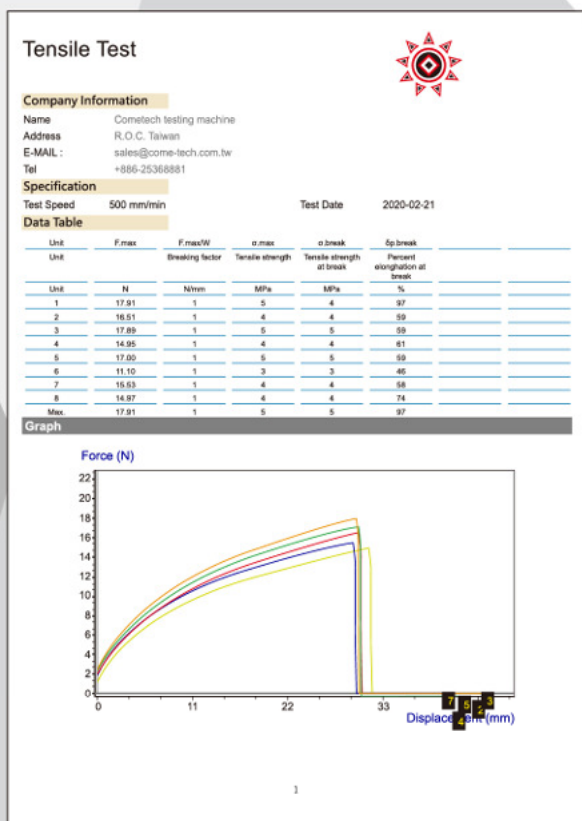

Optional Accessories-Loadcell



Features

- The loadcell is designed with built-in chips that record its specification and calibration parameters. There is no need to reset the loadcell when it is replaced. The relevant parameters can be read directly and there is no limit on the loadcell replacement numbers.
- The accuracy of Comotech grade A/B loadcells can meet international standards.
- Loadcell of various types and capacity is provided according to your requirements.
- The loadcell is conveniently removable with regular tools.

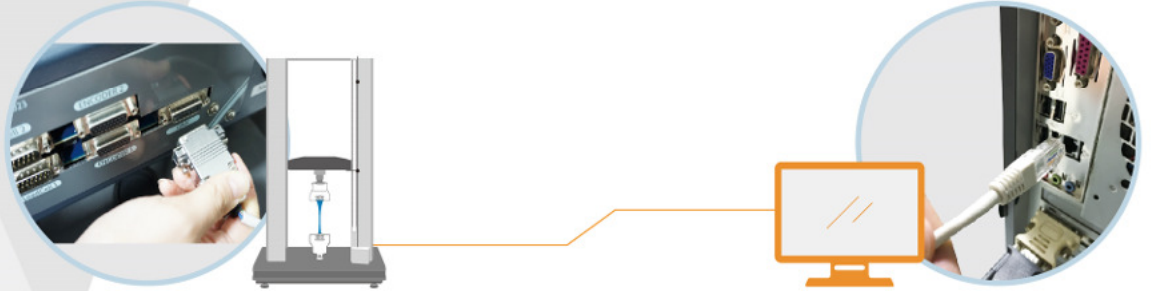

Specification

Controller System	Grade A Loadcell	Grade B Loadcell
D2	1-100% $\pm 0.5\%$	1-100% $\pm 1\%$
Safe Overload	140%	120%

How to Choose a Suitable Loadcell?

- Loadcell capacity is not the larger the better. The recommended range of loadcell application is between 1-99%. Testing force evaluation is suggested before selection of a loadcell; It is recommended to choose one with its capacity twice larger than the maximum testing force.

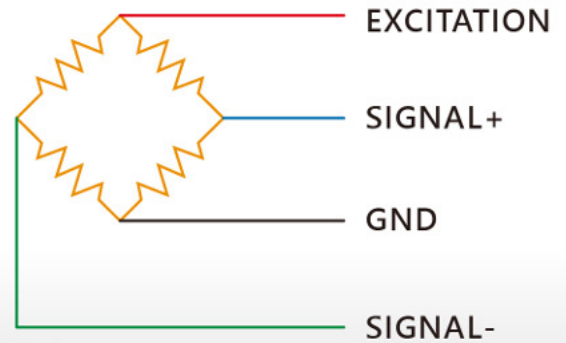

QC-551 Long Extensometer

The Long Extensometer is an essential accessory for measuring extensible material such as rubber, plastic, PE, fabric, webbing, and materials with the elongation higher than 20%. The testing specimen is usually made into a dumb-bell shape, and the gauge length is adjustable according to the length of specimen. The extensometer will automatically detect the elongation during test process.

Specification

Specification	S: Standard	L: Extended
Test Stroke	700mm	1100mm
Gauge Length	15-100mm (adjustable)	
Extensometer Class	C2	
Resolution	0.0125mm	
Operating Force	0.25N	
Specimen Thickness	0-10mm (depending on the jaw face selected)	
Reach of Arms	110mm	

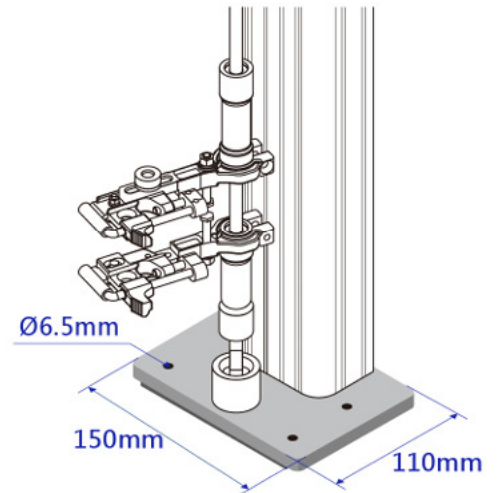

QC-557 Short Extensometer

The Short Extensometer is used for testing rigid plastic, metal, and materials with the elongation lower than 50%. The device has a precise displacement sensor and a compact structure, with resolution up to 0.5µm. Customized specification can be provided when the gauge length or the elongation is higher. In a test with max. load below 20kN, the extensometer can be attached to specimen until it is fractured.

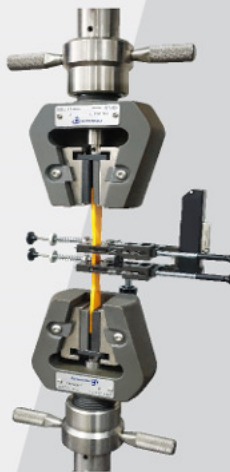

Specification

Specification	QC-557 Short Extensometer
Resolution	0.0005mm
Gauge Length	25mm / 50mm
Max. Stroke	25mm
Distance Clamp-Rod's Head	78mm
Flat Specimen Thickness	0-22mm
Round Specimen Diameter	Ø4.5-Ø21mm
Weight	400g
Extensometer Class	C1
Features	With special jigs to reinforce clamping

QC-558 LVDT Displacement Fixture

The fixture is designed to measure specimen's slight deformation in short distance. It has to be mounted on the side of customized compression platens, bending fixtures or other fixtures to accurately measure the displacement between two platens/fixtures. With the fixture, the machine displacement and stiffness affect to the least degree in the measurement.

Resolution	0.5µm
Max. Measuring Distance	15mm



Grip Application

The grip is an important accessory that affects accuracy, convenience and safety in a test conducted on a material testing machine.

With experience in this field for over 30 years, Cometech provides to-the-point and a complete range of grip/fixture testing solutions according to common test standards.

For more information please refer to <https://www.come-tech.com.tw/en>



Fabric Tensile Test



Compression Test



Webbing Tensile Test



Rubber Tensile Test



Double-sided Adjustable Grip

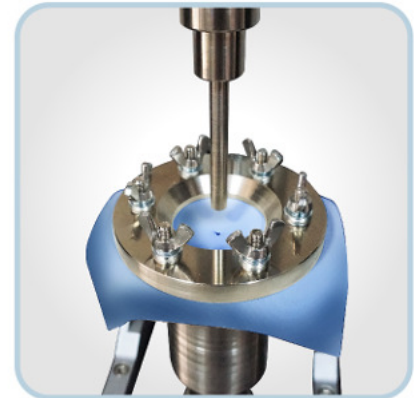

Puncture Test

*Cometech reserves the right to modify product specification.

COMETECH TESTING MACHINES CO.,LTD.

No. 49, Ln. 39, Liancun Rd., Fengyuan Dist., Taichung City 420082, Taiwan (R.O.C.)

Tel: 886-4-25368881 / Fax: 886-4-25368883

E-mail: sales@come-tech.com.tw

URL: <http://www.come-tech.com.tw>

